

COURSE OUTLINE

- Introduction
- Signals and Noise
- **Filtering: Band-Pass Filters 4 – BPF4**
- Sensors and associated electronics

- **From principles to real LIA instruments**
 - Overall gain, Postamplifier and Preamplifier
 - Linearity
 - Switched amplifiers instead of multipliers
- **Lock-in Amplifier with Squarewave Reference**
 - Weighting function; action on sinusoidal signal; action on noise; action on squarewave signal; fundamental-only response
- **Pre-filtering complementary to the LIA Filtering**
 - Pre-filters complementary to LIA. Issues in prefilter design and evaluation.
 - Issues in case of variable signal frequency.
 - Notch filters
- **Reference phase adjustment and waveform conditioning**

From principles to real LIA instruments

In principle:

a LIA consisting simply in a **Phase-Sensitive Detector** provides a flexible and effective band-pass filtering that can achieve **very narrow bandwidth**. It is thus able to recover for measurement with good precision even very small modulated signals buried in much higher noise, down to an ideal limit value $S/N \ll 1$

But in practice:

the non-ideal features of the actual circuits of the PSD set to the recovery of small signals buried in high noise an actual limit much more stringent than the ideal one.

However:

by introducing in the LIA structure modifications and further stages, the hindering features can be counteracted and the actual detection limit can be improved towards the ideal limit. For instance, in real cases **nanoVolt signals** can be extracted from wideband noise with 1000 times (60dB) greater rms value.

High gain for the signal

The modulated input signal is converted by the LIA in a slow demodulated signal, with components from DC to a fairly low frequency limit. **This signal must be supplied to a meter circuit that measures its amplitude, i.e. nowadays ordinarily an ADC.** The LIA output signal must have scale adequate for the ADC (typically 10V full scale), whereas the LIA input signal is very small: therefore, the LIA **must provide high overall gain for the signal.**

Post-Amplifier (after the PSD)

A high-gain amplifier after the PSD (denoted here Post-Amplifier) is employed to raise the demodulated signal to a scale suitable for the ADC.

Notice that the post-amplifier:

1. must be a **DC-coupled** amplifier with upper bandlimit adequate to the demodulated signal
2. receives a signal accompanied by low noise, since it operates after the PSD filtering
3. It has drift of the baseline offset and low-frequency noise, which affect the measurement since they occur **after the PSD** and are **not filtered**

Pre-Amplifier (before the PSD)

If the demodulated signal is very small, comparable or lower than the baseline drift and noise of the post-amplifier referred to its input, the measurement will be spoiled. A **preamplifier before the PSD** is necessary in order to avoid or reduce this drawback.

Notice that the pre-amplifier:

1. processes the modulated input signals, hence it is an **AC coupled** amplifier, either **wide-band** type including the modulation frequency f_m **or narrow-band tuned to f_m**
2. receives a signal accompanied by high noise, because it operates before the PSD
3. may have baseline drift and low-frequency noise, but their role is minor because they are filtered by the PSD (and by the AC-coupled amplifier itself).

WARNING: Signal and Noise MUST stay within the Linear Dynamic Range

In order to obtain the foreseen improvement of S/N, the processing of signal and noise in the LIA must be accurately linear. **Deviations from linearity produce detrimental effects** (self-modulation of the noise, generation of spurious harmonics, etc.), which irrevocably alter the measure and degrade the LIA performance. **The signal and noise must remain well within the linear dynamic range in every stage involved, particularly in the multiplier (and in the preamplifier).**

Wide-Band Preamplifiers and Tuned Preamplifiers

When a **wide-band preamplifier** is employed to raise the level of a very small input signal, a problem arises with very small input $S/N \ll 1$. **The gain required for the signal works on a noise which is much higher than the signal, hence it brings this amplified noise out of the linear dynamic range of the multiplier.**

In such cases, for exploiting the required gain it is necessary to reduce the noise received by the preamplifier with a **pre-filter**. Adequate reduction of the LIA input noise is obtained in many cases with **prefilter passband much wider than that of the LIA.**

Such a prefiltering would be a useless nonsense in an ideal apparatus, but in real cases it is a necessary feature for avoiding nonlinearity in intermediate stages. On the other hand, we will see that a very narrow-band prefilter is not advisable.

Preamplifiers that incorporate prefiltering are currently available from LIA manufacturers; they are called **tuned preamplifiers or selective preamplifiers.**

Linearity limits and problems

- The **multiplier dynamic range** (linear behavior range) does not depend on the gain setting of the preamplifier, it is set just by the multiplier circuit.
- The **preamplifier output dynamic range** is constant, independent of gain setting.
- Therefore, there is a **maximum acceptable input signal** that must not be exceeded for maintaining linear behavior of preamplifier and multiplier; increasing the preamplifier gain by a factor decreases this limit by the same factor
- There is also a **maximum input rms noise** that can be applied maintaining linear behavior; an increase of preamp gain decreases also this limit.
- Also the **post-amplifier** has limited linear range, but problems met are much less severe. In fact, the post-amp receives low-level noise (filtered noise), whereas preamp and multiplier process high-level noise (not filtered or just prefiltered)
- Each setting of preamplifier and post-amplifier gains determines an **input full-scale signal**, i.e an input signal level that produces full-scale LIA output signal.
Note, however, that a given value of input full-scale signal can be obtained with different combinations of preamp gain and post-amp gain

Switched Amplifier Circuits instead of Analog Multipliers

We have seen that modulation with squarewave reference $m(t)$ can be implemented with circuits based simply on switches and amplifiers, avoiding recourse to analog multipliers

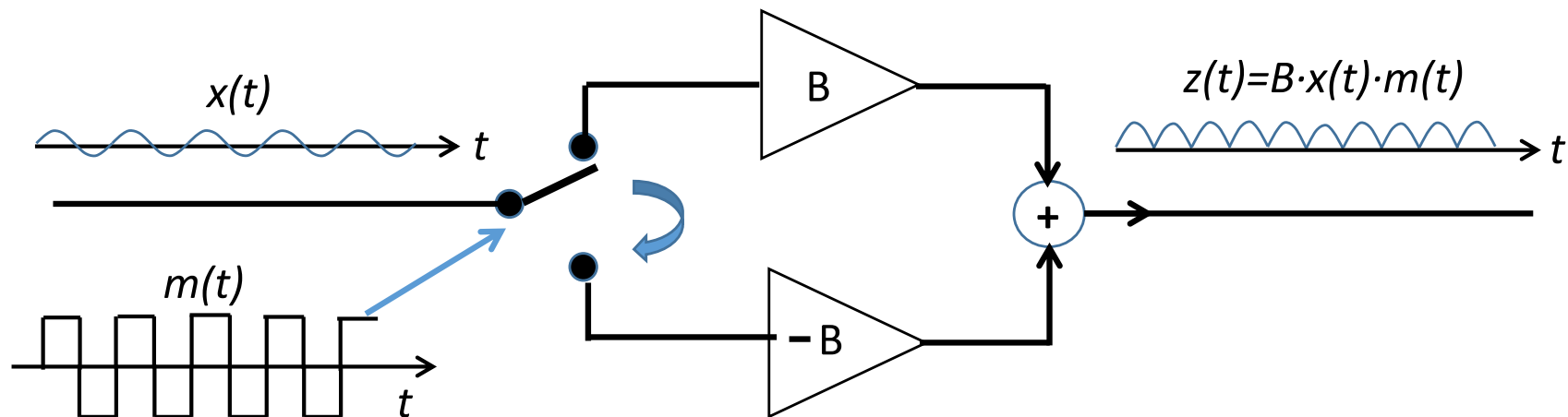

The noise referred to the input, the linearity and the dynamic range of these circuits are remarkably **better than those of analog multiplier circuits** (even high-performance types) because they are limited just by the performance of amplifiers and switch-devices.

Therefore, switched linear circuit configurations are often employed as demodulator stage in LIAs in order to avoid the limitations of analog multipliers.

Lock-in Amplifier with Squarewave Reference

The weighting function $w_L(\alpha)$ of a LIA is the multiplication of reference waveform $m(\alpha)$ (periodic at frequency f_m) and weighting function $w_F(\alpha)$ of the LPF

$$w_L(\alpha) = m(\alpha) \cdot w_F(\alpha)$$

In frequency domain this corresponds to the convolution of the F-transforms

$$W_L(f) = M(f) * W_F(f)$$

Since:

- a) the transform $M(f)$ of a periodic $m(\alpha)$ is composed by lines at f_m (fundamental) and integer multiple frequencies (harmonics)
- b) $W_F(f)$ of the LPF has bandwidth much smaller than f_m

the result of the convolution of $W_F(f)$ by any line of $M(f)$ does not overlap the result by any other line (with very good approximation). We conclude that:

the $W_L(f)$ is a set of **replicas of $W_F(f)$** centered on each line of $M(f)$, **multiplied by the line-weight** and **phase-shifted by the line-phase**.

With very good approximation, the module diagram can thus be obtained simply as

$$|W_L(f)| \cong |M| * |W_F|$$

$m_{sq}(t)$ = symmetrical squarewave (from +1 to -1) at frequency f_m

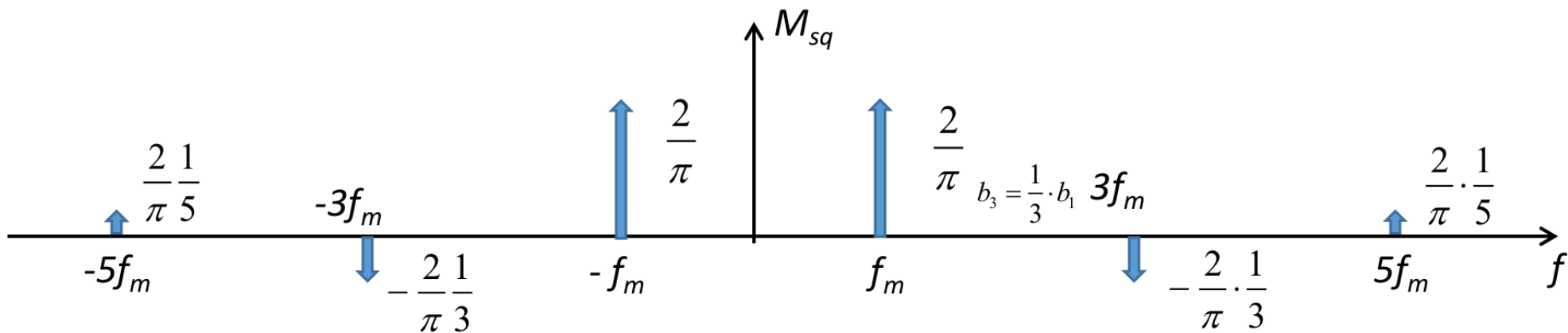
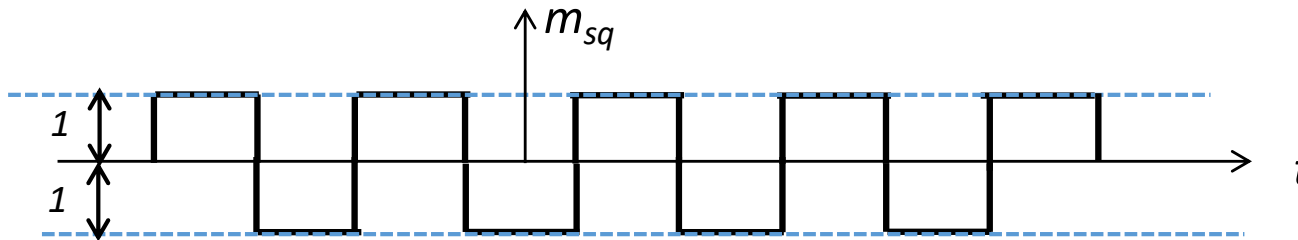

- Only odd-harmonic sinusoidal components
- Components with alternately positive and negative sign, i.e. alternately 0 and π phase
- Component amplitude decreasing as the reciprocal order:

$$b_1 = \frac{2}{\pi} \text{ at fundamental } f_m ; b_3 = \frac{1}{3} \cdot b_1 \text{ at } 3f_m ; b_5 = \frac{1}{5} \cdot b_1 \text{ at } 5f_m ; \dots$$

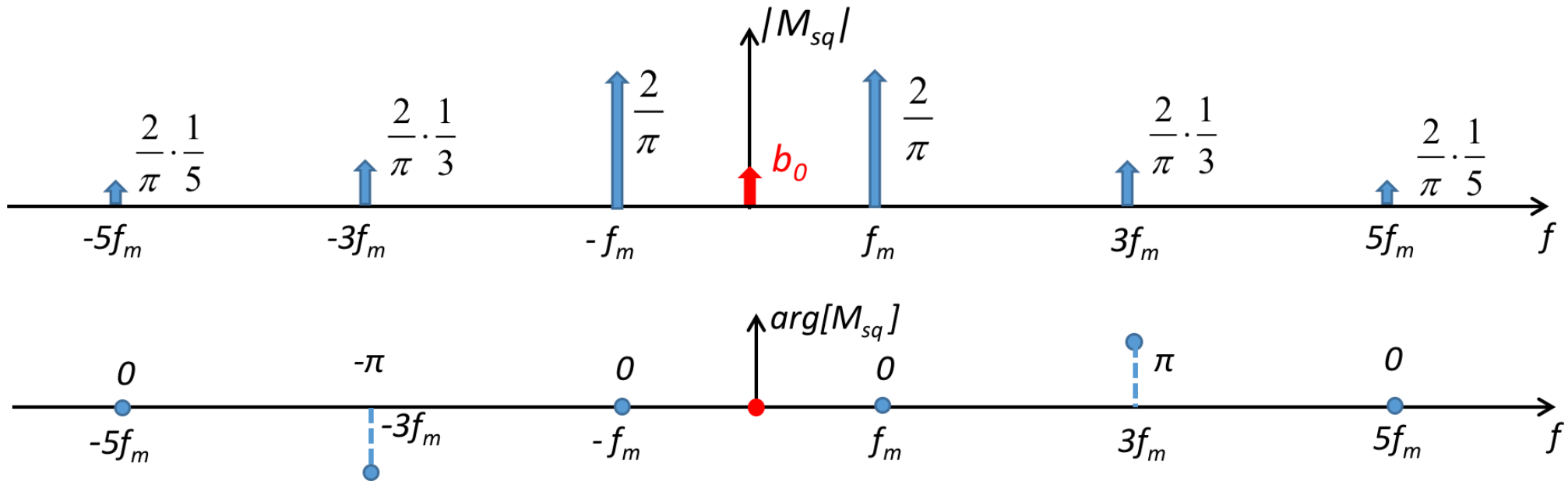

$$M_{sq}(f) = \sum_{k=0}^{\infty} \frac{b_{2k+1}}{2} [\delta(f - f_{2k+1}) + \delta(f + f_{2k+1})] \quad \text{with} \quad b_{2k+1} = \frac{(-1)^k}{(2k+1)} \cdot \frac{4}{\pi}$$

$$k = 0, 1, 2, 3 \dots \quad \text{and} \quad f_{2k+1} = (2k+1)f_m$$

BEWARE: In cases where the squarewave has **non-zero mean value** (e.g. slight asymmetry in amplitude and/or duration of positive and negative lobes) it has also a **DC component with amplitude b_0** given by the ratio of the mean value to the peak amplitude (i.e. by the relative unbalance of positive and negative area)

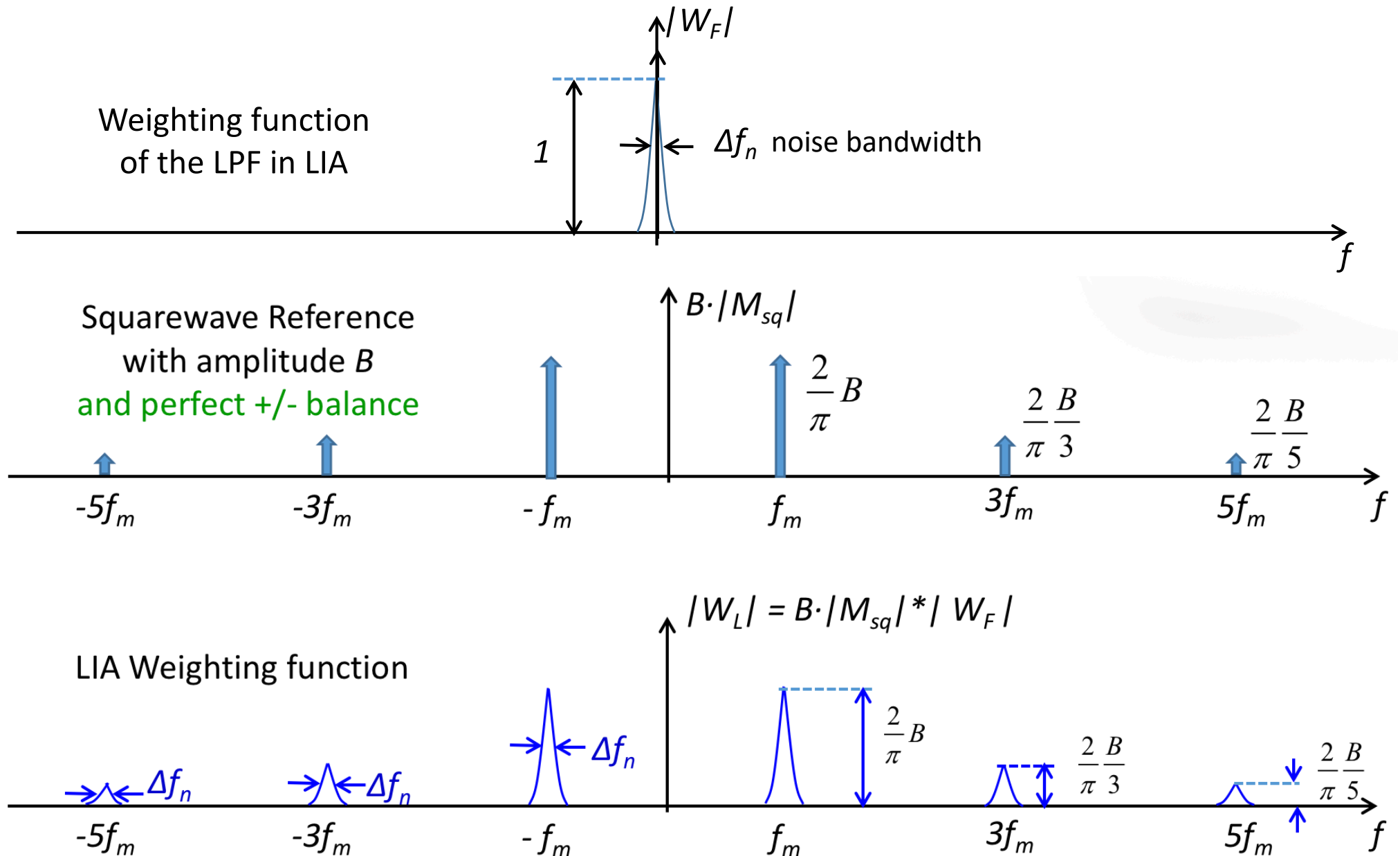

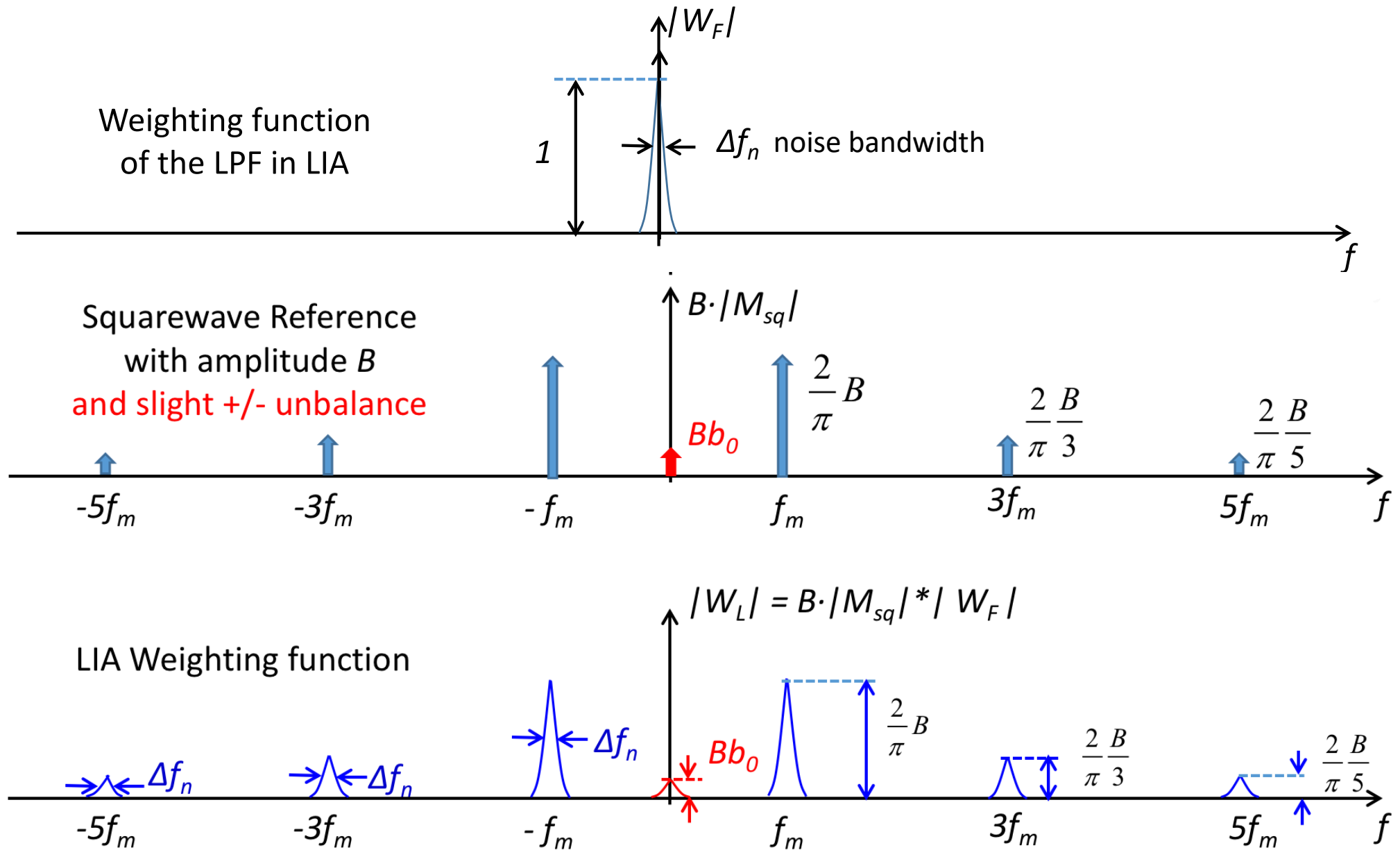

Sinusoidal signal through LIA with Squarewave Reference

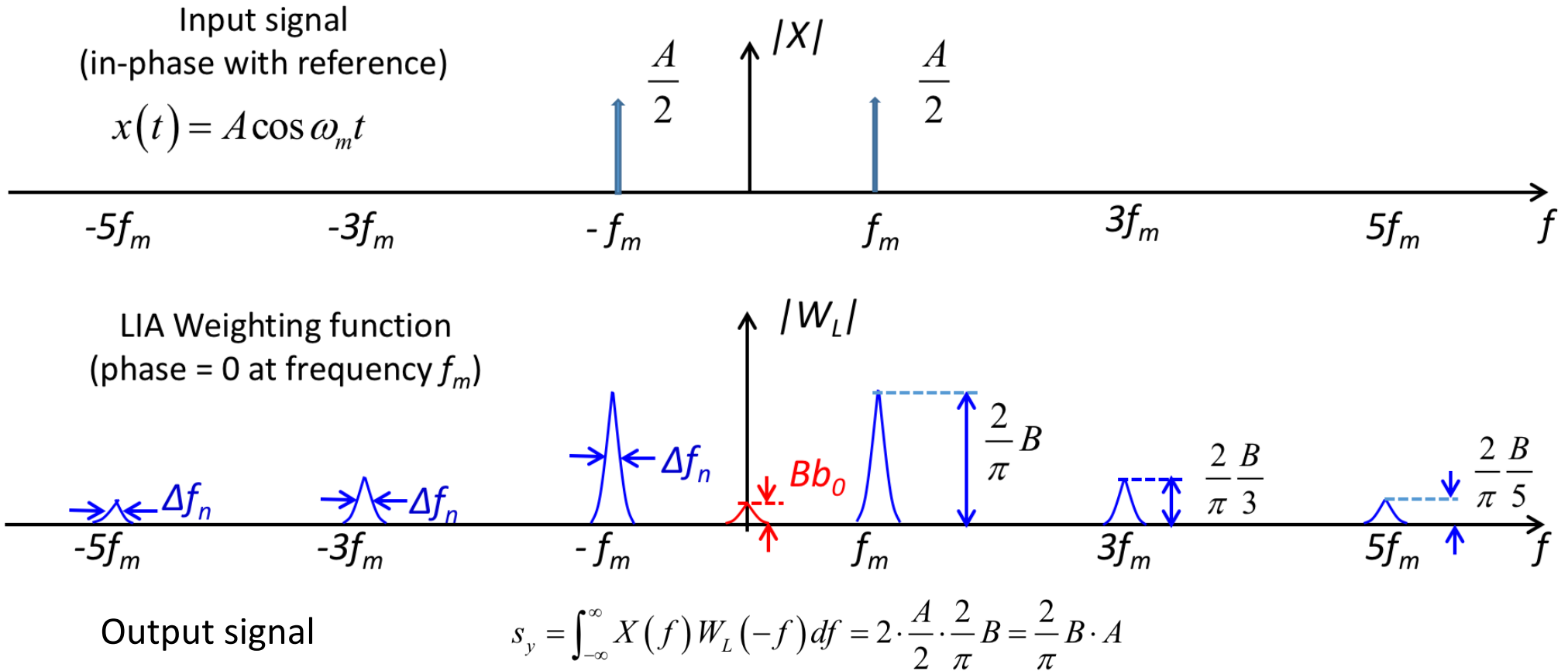

NB This is easily verified in time, since: LIA output $y(t) =$ time average of $z(t) = x(t) \cdot B \cdot m(t) =$ = mean of the in-phase component of the sinusoidal input rectified and multiplied by B

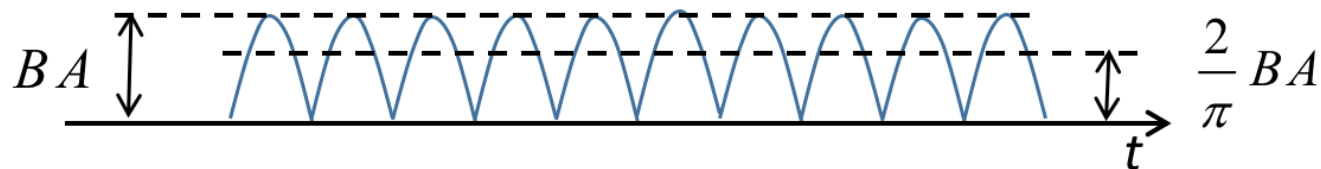

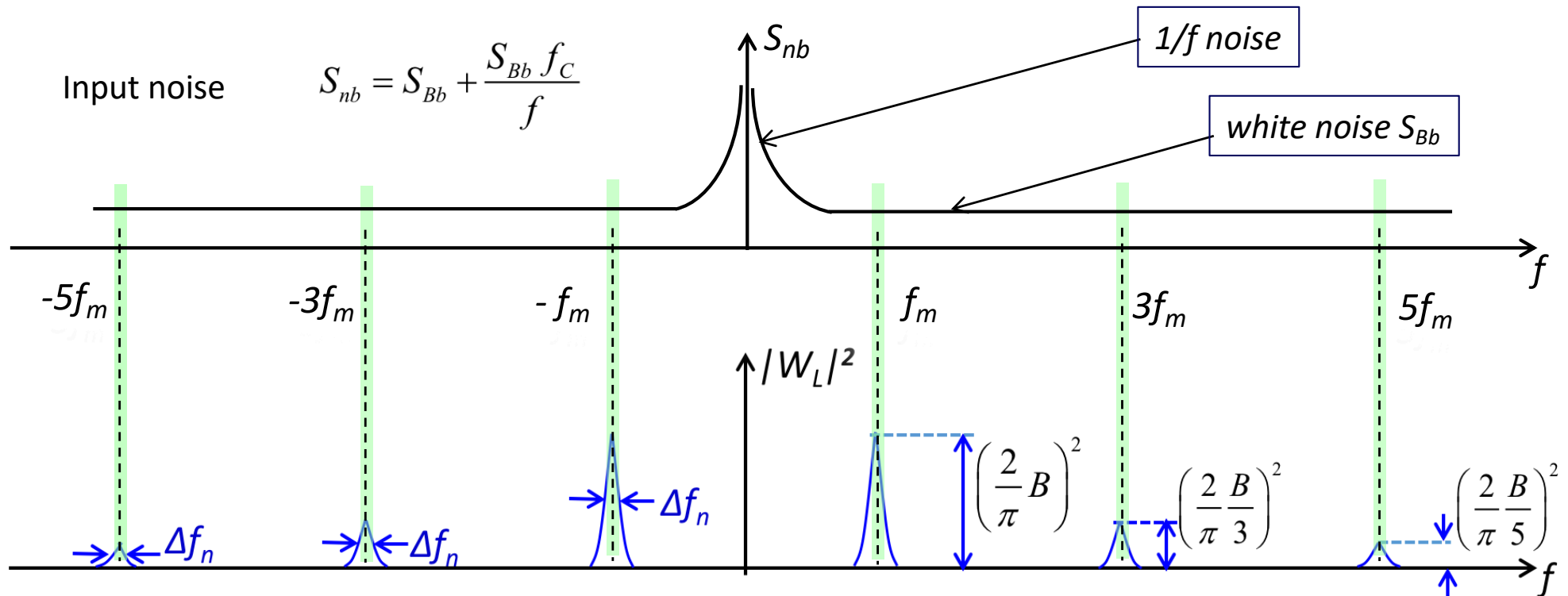

Output Noise $\overline{n_{yL}^2} = \int_{-\infty}^{\infty} S_{nb}(f) |W_L(f)|^2 df = 2 \cdot S_{Bb} \Delta f_n \left(\frac{2B}{\pi}\right)^2 \left[1 + \frac{1}{3^2} + \frac{1}{5^2} + \dots\right]$

The factor $\left[1 + (1/3)^2 + (1/5)^2 + \dots\right] = \pi^2/8 \cong (1,11)^2$ represents the enhanced noise due also to the higher passbands at the harmonic frequencies

$$\overline{n_{yL}^2} = 2S_{Bb} \Delta f_n \left(\frac{2}{\pi}\right)^2 B^2 \frac{\pi^2}{8} = B^2 S_{Bb} \Delta f_n$$

No signal is collected in these passbands. Therefore, the S/N is reduced with respect to the case of sinusoidal reference, but the reduction is moderate.

S/N with Sinusoidal Signal and perfect Squarewave Reference

Output Signal $s_y = \frac{2}{\pi} B \cdot A$ (for sinusoidal input signal in phase)

Output Noise $\overline{n_{yL}^2} = S_{Bb} \Delta f_n B^2$

so that
$$\left(\frac{S}{N}\right)_{L,sqw} = \frac{s_y}{\sqrt{\overline{n_{yL}^2}}} = \frac{A}{\frac{\pi}{2} \sqrt{S_{Bb} \Delta f_n}}$$

which in comparison to the result obtained with sinusoidal reference

$$\left(\frac{S}{N}\right)_{L,\sin} = \frac{A}{\sqrt{2S_{Bb} \Delta f_n}}$$

is just moderately lower

$$\left(\frac{S}{N}\right)_{L,sqw} = \frac{\sqrt{2}}{\frac{\pi}{2}} \left(\frac{S}{N}\right)_{L,\sin} \cong \frac{1}{1,11} \left(\frac{S}{N}\right)_{L,\sin}$$

We will now deal with another case often met in practice: the signal to be measured is a squarewave in phase with the squarewave reference

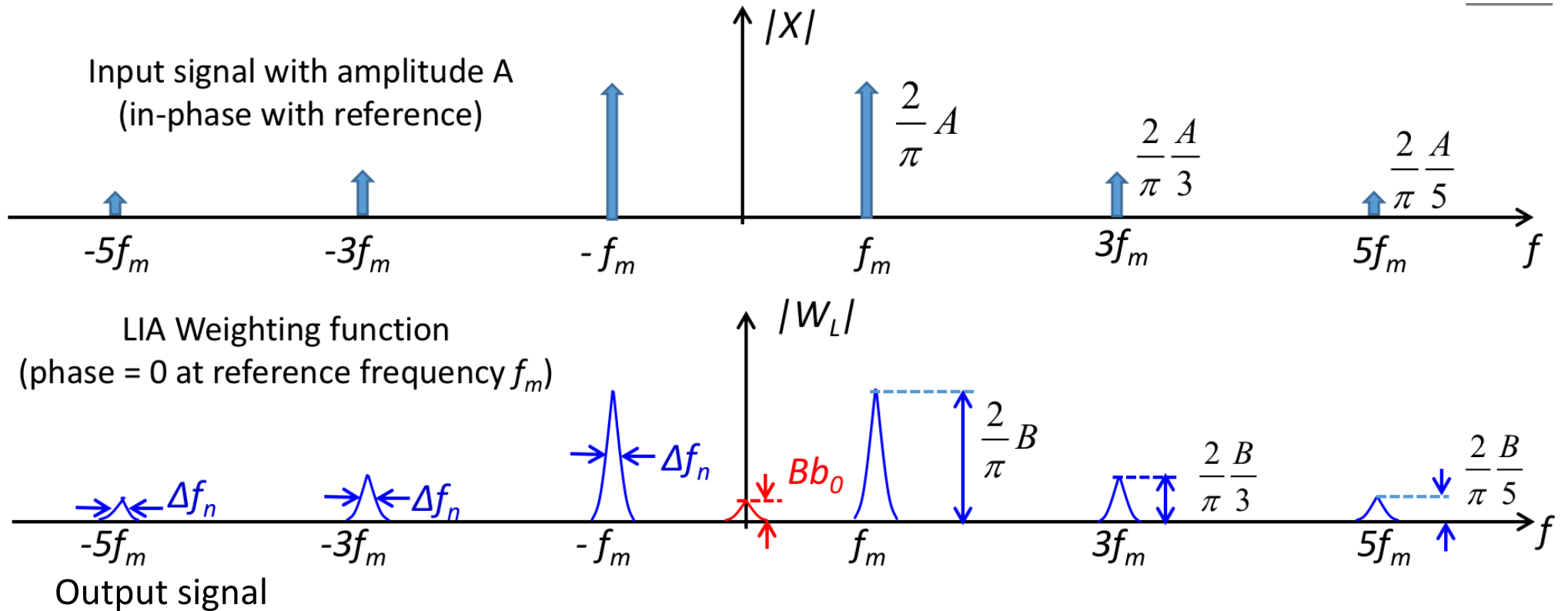

$$s_y = \int_{-\infty}^{\infty} X(f) W_L(-f) df = 2 \cdot \left[\frac{2}{\pi} A \cdot \frac{2}{\pi} B \right] \cdot \left[1 + \frac{1}{3^2} + \frac{1}{5^2} + \dots \right] = 2 \cdot \left[\frac{2}{\pi} A \cdot \frac{2}{\pi} B \right] \frac{\pi^2}{8} = AB$$

NB1: This is easily verified in time, since: LIA output $y(t)$ = time average of $z(t) = x(t) \cdot B m(t)$

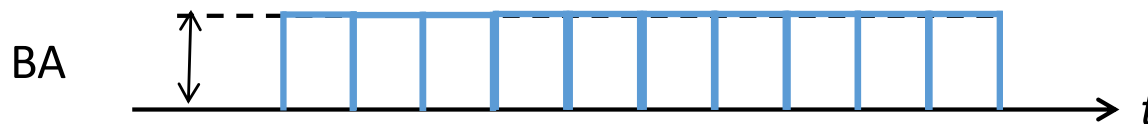

NB2: As concerns the **output noise**, it has already been discussed

Output Signal $s_y = B \cdot A$ for squarewave input signal in phase

Output Noise $\overline{n_{yL}^2} = S_{Bb} \Delta f_n B^2$

so that
$$\left(\frac{S}{N}\right)_{L,sqw} = \frac{s_y}{\sqrt{\overline{n_{yL}^2}}} = \frac{A}{\sqrt{S_{Bb} \Delta f_n}}$$

However, for equal amplitude A the squarewave signal has double power and correspondingly higher S/N

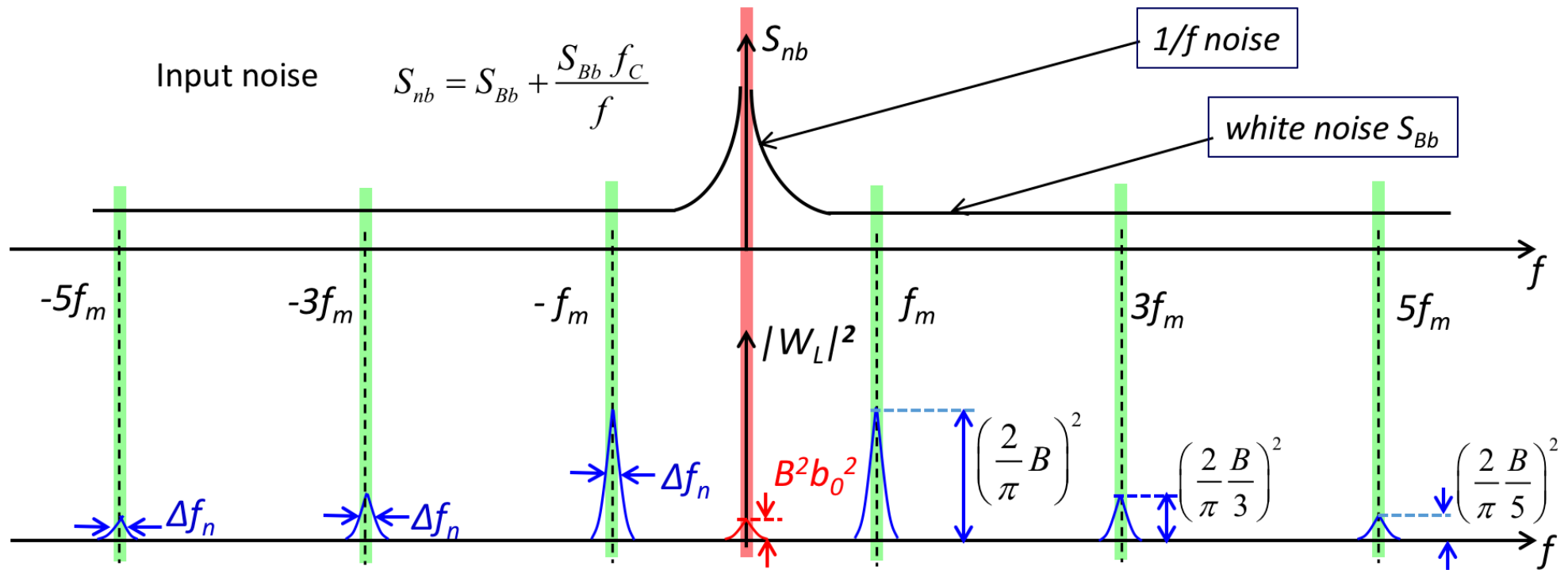

A squarewave with non-zero-mean generates a spurious band at $f=0$ with additional noise

$$\overline{n_{yL0}^2} = \widehat{S}_{nb} \Delta f_n B^2 b_0^2$$

Because of the $1/f$ noise, the mean density \widehat{S}_{nb} in the band can be very high $\widehat{S}_{nb} \gg S_{Bb}$ so that even with small spurious band $b_0 \ll 1$ the added noise $\overline{n_{yL0}^2}$ can be comparable to the basic term $\overline{n_{yL}^2}$ or even larger

$$\frac{\overline{n_{yL0}^2}}{\overline{n_{yL}^2}} = \frac{\widehat{S}_{nb}}{S_{Bb}} b_0^2$$

	SINUSOIDAL Reference	SQUAREWAVE Reference
<p>SINUSOIDAL Signal</p> <p>amplitude A</p> <p>power $P = \frac{A^2}{2}$</p> <p>A_{\min} minimum measurable amplitude (at S/N=1)</p>	$\frac{S}{N} = \frac{A}{\sqrt{2}\sqrt{S_{Bb}\Delta f_n}} = \frac{\sqrt{P}}{\sqrt{S_{Bb}\Delta f_n}}$	$\frac{S}{N} = \frac{A}{\frac{\pi}{2}\sqrt{S_{Bb}\Delta f_n}}$ $= \frac{\sqrt{P}}{\frac{\pi}{2\sqrt{2}}\sqrt{S_{Bb}\Delta f_n}}$
	$A_{\min} = \sqrt{2}\sqrt{S_{Bb}\Delta f_n} = \mathbf{1,41}\sqrt{S_{Bb}\Delta f_n}$	$A_{\min} = \frac{\pi}{2}\sqrt{S_{Bb}\Delta f_n}$ $= \mathbf{1,57}\sqrt{S_{Bb}\Delta f_n}$
<p>SQUAREWAVE Signal</p> <p>amplitude A</p> <p>power $P = A^2$</p> <p>A_{\min} minimum measurable amplitude (at S/N=1)</p>	$\frac{S}{N} = \frac{A}{\frac{\pi}{2\sqrt{2}}\sqrt{S_{Bb}\Delta f_n}} = \frac{\sqrt{P}}{\frac{\pi}{2\sqrt{2}}\sqrt{S_{Bb}\Delta f_n}}$	$\frac{S}{N} = \frac{A}{\sqrt{S_{Bb}\Delta f_n}} = \frac{\sqrt{P}}{\sqrt{S_{Bb}\Delta f_n}}$
	$A_{\min} = \frac{\pi}{2\sqrt{2}}\sqrt{S_{Bb}\Delta f_n} = \mathbf{1,11}\sqrt{S_{Bb}\Delta f_n}$	$A_{\min} = \sqrt{S_{Bb}\Delta f_n}$

Reference: phase adjustment and waveform conditioning

In order to be useful as **reference** for measuring with a LIA a given periodic signal, the **essential necessary features** of an auxiliary signal are:

- 1) fundamental **frequency identical** to the signal
- 2) **constant phase difference φ** with respect to the signal.
(NB: not necessarily $\varphi=0$, but it is necessary that $\varphi = \text{constant}$!)

If the auxiliary signal has high and constant amplitude, negligible noise and clean waveform (free from harmonics), it can be directly adjusted to $\varphi=0$ with a phase-shifter filter and supplied to the multiplier as reference waveform.

- An adjustable phase-shifter is currently included in LIAs for re-phasing the reference. The phase adjustment can be controlled manually by observing the output signal amplitude, which is maximum when $\varphi=0$.
- Many LIA's besides the adjustable phase shifter include an additional filter, which gives phase shift φ_a switchable from $\varphi_a=\pi/2$ to $\varphi_a=0$. Setting $\varphi_a=\pi/2$, when $\varphi=0$ is reached the signal is in quadrature and the output is zero. Notice that observing the output signal while φ is varied it is easier to identify when it reaches zero rather than when it reaches the maximum. After the adjustment to $\varphi=0$, the additional filter is switched back to $\varphi_a=0$ and the LIA is ready to operate.

By exploiting the a well known trigonometric equation

$$\cos \alpha \cos \beta = \frac{1}{2} \cos(\alpha - \beta) + \frac{1}{2} \cos(\alpha + \beta)$$

in cases with sinusoidal signal and sinusoidal reference

$$x(t) = A \cos(2\pi f_S t)$$

$$m(t) = B \cos(2\pi f_m t + \varphi_m)$$

the result is directly obtained, since $f_S = f_m$

$$y(t) = x(t) \cdot m(t) = \frac{AB}{2} \cos[\varphi_m] + \frac{AB}{2} \cos[2\pi(2f_S)t + \varphi_m]$$